

Seamless circular austenitic stainless steel tubes
subject to special requirements

Technical delivery conditions

DIN
17458

Nahtlose kreisförmige Rohre aus austenitischen nichtrostenden Stählen für besondere Anforderungen; technische Lieferbedingungen

This standard, together with DIN 17440, DIN 17441, DIN 17455, DIN 17456 and DIN 17457 (July 1985 editions), supersedes DIN 17440, December 1972 edition.

In keeping with current practice in standards published by the International Organization for Standardization (ISO), a comma has been used throughout as the decimal marker.

See Explanatory notes for connection with International Standard ISO 2604/2 - 1975, published by the International Organization for Standardization (ISO).

The subclause marked with a single dot ● give specifications which are to be agreed upon at the time of ordering.

The subclauses marked with two dots ●● give specifications which are optional and may be agreed upon at the time of ordering.

Contents

	Page		Page
1 Field of application	1	5.10 Non-destructive testing	9
2 General	1	5.11 Dimensions, masses per unit length and permissible deviations	9
2.1 Concept	1	5.12 Physical properties	9
2.2 Test classes	1	6 Tests to be carried out and documents on materials testing	9
3 Classification into grades	1	6.1 General	9
4 Designation and ordering	1	6.2 Test site	9
5 Requirements	2	6.3 Scope of test programme	9
5.1 Manufacturing process	2	6.4 Sampling and sample preparation	10
5.2 As delivered condition	2	6.5 Procedure	11
5.3 Chemical composition	2	6.6 Retests	12
5.4 Mechanical and technological properties	2	6.7 Documents on materials testing	12
5.5 Weldability	2	7 Marking	12
5.6 Further processing and heat treatment	2	8 Complaints	12
5.7 Corrosion resistance	2	Appendix A	13
5.8 Type of condition and appearance of surface	9		
5.9 Leak tightness	9		

1 Field of application

1.1 This standard applies to seamless circular tubes and pipes (hereinafter briefly referred to as tubes) subject to special requirements and made from the austenitic stainless steels listed in table 1. These tubes are predominantly used in the construction of pressure vessels, chemical plant and pipework.

The limits of application and other specifications given in this standard shall apply except in cases where other specifications are given in codes of practice for specific fields of application, e.g. the *Technische Regeln Druckbehälter (TRB)* (Technical rules on pressure vessels), *Merkblätter der Arbeitsgemeinschaft Druckbehälter* (Instruction sheets of the Study group on pressure vessels).

1.2 This standard does not apply to general purpose seamless circular stainless steel tubes (see DIN 17456).

2 General**2.1 Concept**

Steels which are particularly resistant to chemically aggressive agents are considered to be stainless steels; they generally have a chromium content of not less than 12% by mass and a carbon content not exceeding 1,2% by mass.

2.2 Test classes

Tubes complying with the requirements of this standard may be supplied as test class 1 or test class 2 tubes. Test class 2 tubes are distinguished from test class 1 tubes by their having been subjected to a more extensive test programme.

● The selection of the test class is at the purchaser's discretion.

3 Classification into grades

This standard covers tubes made from the steel grades listed in table 1.

● The selection of the steel grade is at the purchaser's discretion.

4 Designation and ordering

4.1 The standard designation for tubes complying with this standard shall give in the following order:

- the term "tube";
- DIN number of the dimensional standard (e.g. DIN 2462 Part 1);
- characteristic dimensions of tube (outside diameter × wall thickness);

Continued on pages 2 to 16

上海... 17338 ... 日

- number of the present standard (DIN 17458);
- symbol or material number for the steel grade (see table 1);
- symbol for the type of condition of the tube (see table 6).

Example:

A seamless tube conforming to this standard, with an outside diameter of 88,9 mm and a wall thickness of 4 mm as specified in DIN 2462 Part 1, made from X 6 CrNiNb 18 10 steel (material number 1.4550), in the cold worked, heat treated and pickled condition (h), shall be designated as follows:

Tube DIN 2462 – 88,9 × 4
DIN 17458 – X 6 CrNiNb 18 10 – h
or Tube DIN 2462 – 88,9 × 4
DIN 17458 – 1.4550 – h

4.2 ● In addition to the standard designation as given in subclause 4.1, the purchaser shall always state in his order the required quantity (e.g. the total length to be supplied), the test class, the type of length (see DIN 2462 Part 1), the length of the individual tube in the case of specified lengths and exact lengths, the tolerance class for diameter and wall thickness as specified in DIN 2462 Part 1, the type of document on materials testing as specified in DIN 50 049 and, if required, also the relevant technical specification.

Example of an order:

**1000 m tube DIN 2462 – 88,9 × 4
DIN 17458 – 1.4550 – h
test class 1, in specified lengths of 6 m,
tolerance class D2, T3,
accompanied by document DIN 50 049 – 3.1 B**

4.3 ●● In addition to this, further details may be agreed at the time of ordering, as described in the subclause marked with two dots.

5 Requirements

5.1 Manufacturing process

5.1.1 The process employed for making the steels used to manufacture the tubes covered by this standard is at the manufacturer's discretion, unless a special steelmaking process has been specified at the time of ordering.

5.1.1.1 ●● If so agreed, the purchaser shall be informed on the steelmaking process used.

5.1.2 Tubes covered by this standard shall be manufactured by hot or cold rolling, hot pressing or cold drawing or a combination of these processes.

Unless otherwise agreed at the time of ordering, the process used to manufacture the tubes is at the manufacturer's discretion.

5.2 As delivered condition

The tubes may be supplied in one of the conditions specified in table 6 (see subclause 5.8). The guideline data given in table 5 shall be taken into consideration with regard to heat treatment. In the case of hot pressed austenitic steel tubes, the requirements for proper heat treatment shall be deemed to have been met if the tubes, after hot working and solution annealing, have been quenched in water.

5.3 Chemical composition

5.3.1 Cast analysis

The chemical composition of the steels determined in the cast analysis¹⁾ shall be specified in table 1. Slight deviations from these values are permitted subject to agreement with

the purchaser or his representative if the mechanical properties, weldability and corrosion resistance of the steel conform to the requirements specified in this standard.

5.3.2 Product analysis

When testing the chemical composition of the finished product, the deviations shown in table 2 from the values specified in table 1 are permitted.

5.4 Mechanical and technological properties

5.4.1 The 0,2% and 1% proof stresses, the tensile strength, the elongation after fracture and the impact energy determined for the tube material shall conform to the values specified in table 3, which apply for tubes in the as delivered condition specified in subclause 5.2 and for the test conditions specified in subclauses 6.4 and 6.5 of this standard.

5.4.1.1 ●● The mechanical properties do not apply for condition f described in table 6. If required, these shall be agreed at the time of ordering.

5.4.2 The values listed in table 4 shall apply for the elevated temperature 0,2% and 1% proof stresses.

5.4.3 Guideline data relating to creep strength are given in Appendix A.

5.4.4 The tubes shall comply with the requirements to be verified in the technological tests specified in subclauses 6.5.4 to 6.5.7.

5.4.5 Tubes made from steel grades specified in this standard are suitable for hot working.

5.4.6 Tubes made from the steel grades specified in this standard are particularly suited for cold working (e.g. bending) in the "solution annealed and quenched" condition. It should be noted that the corrosion resistance and the mechanical and physical properties are changed by cold working.

5.5 Weldability

5.5.1 Tubes made from the steel grades specified in this standard are suitable for arc welding.

5.5.2 According to DIN 8528 Part 1 however, weldability is dependent not only on the grade of steel but also on the conditions during welding, on the design and the operating conditions of the structural component.

5.5.3 Any filler metal required shall be selected on the basis of DIN 8556 Part 1 taking the intended application, the stress, the welding process and other recommendations into consideration.

5.6 Further processing and heat treatment

See table 5 for guideline data on heat treatment in the fabrication of the tubes and on further processing, and also for guideline data on hot working as part of further processing.

5.7 Corrosion resistance

5.7.1 The corrosion resistance of tubes complying with this standard under the effect of the various corrosive stresses found in use is not the subject of this standard as it cannot be covered by a requirement of general validity.

5.7.1.1 ●● If necessary, specific corrosion tests may be agreed at the time of ordering. The conditions and the evaluation of the results of testing shall also be specified on this occasion.

¹⁾ When sequential castings are supplied, as is possible in the case of continuously cast tubes, the term "cast" should be read as "casting units".

Table 1. Steel grades and chemical composition determined in the cast analysis¹⁾

Steel grade		Material number	% by mass						Others ³⁾
Symbol ²⁾	C max.		Cr	Mo	Ni				
X 5 CrNi 18 10	0,07	1.4301	17,0 to 19,0	-	8,5 to 10,5	-	-	-	
X 2 CrNi 19 11	0,030	1.4306	18,0 to 20,0	-	10,0 to 12,5	-	-	-	
X 2 CrNiN 18 10	0,030	1.4311	17,0 to 19,0	-	8,5 to 11,5	-	N: 0,12 to 0,22	-	
X 6 CrNiTi 18 10	0,08	1.4541	17,0 to 19,0	-	9,0 to 12,0	-	Ti: 5 × % C, up to 0,80	-	
X 6 CrNiNb 18 10	0,08	1.4550	17,0 to 19,0	-	9,0 to 12,0	-	Nb: 10 × % C, up to 1,00 ⁴⁾	-	
X 5 CrNiMo 17 12 2	0,07	1.4401	16,5 to 18,5	2,0 to 2,5	10,5 to 13,5	-	-	-	
X 2 CrNiMo 17 13 2	0,030	1.4404	16,5 to 18,5	2,0 to 2,5	11,0 to 14,0	-	-	-	
X 6 CrNiMoTi 17 12 2	0,08	1.4571	16,5 to 18,5	2,0 to 2,5	10,5 to 13,5	-	Ti: 5 × % C, up to 0,80	-	
X 6 CrNiMoNb 17 12 2	0,08	1.4580	16,5 to 18,5	2,0 to 2,5	10,5 to 13,5	-	Nb: 10 × % C, up to 1,00 ⁴⁾	-	
X 2 CrNiMoN 17 13 3	0,030	1.4429	16,5 to 18,5	2,5 to 3,0	11,5 to 14,5	-	N: 0,14 to 0,22; S ≤ 0,025	-	
X 2 CrNiMo 18 14 3	0,030	1.4435	17,0 to 18,5	2,5 to 3,0	12,5 to 15,0	-	S ≤ 0,025	-	
X 5 CrNiMo 17 13,3	0,07	1.4436	16,5 to 18,5	2,5 to 3,0	11,0 to 14,0	-	S ≤ 0,025	-	
X 2 CrNiMoN 17 13 5	0,030	1.4439	16,5 to 18,5	4,0 to 5,0	12,5 to 14,5	-	N: 0,12 to 0,22; S ≤ 0,025	-	

- 1) Elements not quoted in this table in respect of the individual steel grades shall not be added deliberately to the steel without the purchaser's consent, except for the purpose of finishing the melt. Such elements shall in no way impair the usability or processability of the steel, e.g. its weldability, nor shall they affect the properties specified in this standard.
- 2) The symbols given in the December 1972 edition of DIN 17440 may continue to be used during the period of validity of this standard (see comparison table in the Explanatory notes).
- 3) Unless otherwise specified, $P \leq 0,045\%$, $S \leq 0,030\%$, $Si \leq 1,0\%$, $Mn \leq 2,0\%$.
- 4) Tantalum determined together with niobium and expressed in the form of niobium content.

Table 2. Amounts by which the chemical composition in the product analysis may deviate from the limit values specified for the cast analysis

Element	Limit values specified for the cast analysis as in table 1 % by mass	Permissible deviations ¹⁾ % by mass
Carbon C	$\leq 0,030$ $> 0,030 \leq 0,08$	+ 0,005 + 0,01
Silicon (Si)	$\leq 1,0$	+ 0,05
Manganese (Mn)	$\leq 2,0$	+ 0,04
Phosphorus (P)	$\leq 0,045$	+ 0,005
Sulfur (S)	$\leq 0,030$	+ 0,005
Nitrogen (N)	$\leq 0,22$	$\pm 0,01$
Chromium (Cr)	$\geq 16,5 \leq 20,0$	$\pm 0,20$
Molybdenum (Mo)	$\geq 2,0 \leq 5,0$	$\pm 0,10$
Nickel (Ni)	$\geq 8,5 < 10,0$ $\geq 10,0 \leq 15,0$	$\pm 0,10$ $\pm 0,15$
Niobium (Nb)	$\leq 1,00$	$\pm 0,05$
Titanium (Ti)	$\leq 0,80$	$\pm 0,05$
¹⁾ If several product analyses are carried out for a single cast and if these elements show contents for a single element outside the range specified for the cast analysis, this content shall either exceed the permissible maximum content or be below the permissible minimum content, but not both at the same time for one cast.		

Table 3. Mechanical properties of the steels at ambient temperature in the as delivered condition specified in table 6 and their resistance to intercrystalline corrosion (applicable to wall thicknesses up to 50 mm) ¹⁾

Steel grade Symbol	Material number	Heat treatment condition ²⁾	Minimum 0,2% proof stress N/mm ²	Minimum 1% proof stress N/mm ²	Tensile strength ²⁾ N/mm ²	Minimum elongation after fracture ²⁾ ($L_0 = 5 d_0$) %		Minimum impact energy ³⁾ (ISO V-notch test pieces) J		Resistance to intercrystalline corrosion ⁴⁾	
						Longitudinal	Transverse	Longitudinal	Transverse	in the as delivered condition	after further processing by welding without heat treatment
X 5 CrNi 18 10	1.4301	Solution annealed and quenched	195	230	500 to 700	40	35	85	55	g. ⁵⁾	g. ⁵⁾
X 2 CrNi 19 11	1.4306		180	215	460 to 680	40	35			g.	g.
X 2 CrNiN 18 10	1.4311		270	305	550 to 760	35	30			g.	g.
X 6 CrNiTi 18 10 ⁶⁾	1.4541 ⁶⁾		200	235	500 to 730	35	30			g.	g.
X 6 CrNiTi 18 10 ⁷⁾	1.4541 ⁷⁾		180	215	460 to 680	35	30			g.	g.
X 6 CrNiNb 18 10	1.4550		205	240	510 to 740	35	30			g.	g.
X 5 CrNiMo 17 12 2	1.4401	Solution annealed and quenched	205	240	510 to 710	40	30	85	55	g. ⁵⁾	g. ⁵⁾
X 2 CrNiMo 17 13 2	1.4404		190	225	490 to 690	40	30			g.	g.
X 6 CrNiMoTi 17 12 2 ⁶⁾	1.4571 ⁶⁾		210	245	500 to 730	35	30			g.	g.
X 6 CrNiMoTi 17 12 2 ⁷⁾	1.4571 ⁷⁾		190	225	490 to 690	35	30			g.	g.
X 6 CrNiMoNb 17 12 2	1.4580		215	250	510 to 740	35	30			g.	g.
X 2 CrNiMoN 17 13 3	1.4429	Solution annealed and quenched	295	330	580 to 800	35	30	85	55	g.	g.
X 2 CrNiMo 18 14 3	1.4435		190	225	490 to 690	40	30			g.	g.
X 5 CrNiMo 17 13 3	1.4436		205	240	510 to 710	40	30			g. ⁵⁾	g. ⁵⁾
X 2 CrNiMoN 17 13 5	1.4439	Solution annealed and quenched	285	315	580 to 800	35	30	85	55	g.	g.

1) For greater wall thicknesses, the values shall be specified by agreement.

2) The values specified do not apply for condition f described in table 6. For this condition, they shall be agreed at the time of ordering, if required.

3) Average value from three test pieces at ambient temperature. Only one individual value of the test unit may be less than this value by a maximum of 30%.

4) When tested in accordance with DIN 50 914, g. means existing up to the limit temperatures listed in the last column of table 4.

5) Only for wall thicknesses not exceeding 6 mm.

6) Not to be used for tubes manufactured by hot working or subjected to further processing.

7) To be used for tubes manufactured by hot working or subjected to further processing.

Table 4. Minimum values of elevated temperature 0,2 % and 1 % proof stresses and guideline values for the limit temperature in the case of intercrystalline corrosive stress

Steel grade Symbol	Material number	Heat treatment condition	0,2% proof stress at a temperature, in °C, of										1% proof stress at a temperature, in °C, of										Limit temperature 1) °C		
			50	100	150	200	250	300	350	400	450	500	550	50	100	150	200	250	300	350	400	450		500	550
X5CrNi1810 X2CrNi1911 X2CrNiN1810 X6CrNiTi1810 ²⁾ X6CrNiTi1810 ³⁾ X6CrNiNb1810	1.4301	Solution annealed and quenched	177	157	142	127	118	110	104	98	95	92	90	211	191	172	157	145	135	129	125	120	120	300 ⁴⁾	
	1.4306		162	147	132	118	108	100	94	89	85	81	80	201	181	162	147	137	127	121	116	112	109	108	350
	1.4311		245	205	175	157	145	136	130	125	121	119	118	280	240	210	187	175	167	161	156	152	149	147	400
	1.4541 ²⁾		190	176	167	157	147	136	130	125	121	119	118	222	208	195	185	175	167	161	156	152	149	147	400
	1.4541 ³⁾		162	147	132	118	108	100	94	89	85	81	80	201	181	162	147	137	127	121	116	112	109	108	400
	1.4550		191	177	167	157	147	136	130	125	121	119	118	226	211	196	186	177	167	161	156	152	149	147	400
X5CrNiMo17122 X2CrNiMo17132 X6CrNiMoTi17122 ²⁾ X6CrNiMoTi17122 ³⁾ X6CrNiMoNb17122	1.4401	Solution annealed and quenched	196	177	162	147	137	127	120	115	112	110	108	230	211	191	177	167	156	150	144	141	139	137	300 ⁴⁾
	1.4404		182	166	152	137	127	118	113	108	103	100	98	217	199	181	167	157	145	139	135	130	128	127	400
	1.4571 ²⁾		202	185	177	167	157	145	140	135	131	129	127	234	218	206	196	186	175	169	164	160	158	157	400
	1.4571 ³⁾		182	166	152	137	127	118	113	108	103	100	98	217	199	181	167	157	145	139	135	130	128	127	400
	1.4580		206	186	177	167	157	145	140	135	131	129	127	240	221	206	196	186	175	169	164	160	158	157	400
	1.4429		265	225	197	178	165	155	150	145	140	138	136	300	260	227	208	195	185	180	175	170	168	166	400
X2CrNiMo18143 X5CrNiMo17133	1.4435	Solution annealed and quenched	182	166	152	137	127	118	113	108	103	100	98	217	199	181	167	157	145	139	135	130	128	127	400
	1.4436		196	177	162	147	137	127	120	115	112	110	108	230	211	191	177	167	156	150	144	141	139	137	300 ⁴⁾
X2CrNiMoN17135	1.4439	Solution annealed and quenched	260	225	200	185	175	165	155	150	-	-	290	255	230	210	200	190	180	175	-	-	-	400	

1) Up to these temperatures, the material will, within 100 000 hours, not have changed so as to show susceptibility to intercrystalline corrosion.
 2) Not to be used for tubes manufactured by hot working or subjected to further processing.
 3) To be used for tubes manufactured by hot working or subjected to further processing.
 4) Only for wall thicknesses not exceeding 6 mm.

Table 5. **Guideline data for the heat treatment during fabrication and further processing of tubes and guideline data for hot working as part of further processing**

Steel grade		Heat treatment during fabrication and further processing		Solution annealing temperature ¹⁾	
Symbol	Material number	Solution annealing temperature ¹⁾ °C	Quenching in	Temperature °C	Type of cooling
X 5 CrNi 18 10 X 2 CrNi 19 11 X 2 CrNiN 18 10	1.4301 1.4306 1.4311	1000 to 1080	Water, air ²⁾	1150 to 750	Air
X 6 CrNiTi 18 10 X 6 CrNiNb 18 10 X 5 CrNiMo 17 12 2 X 2 CrNiMo 17 13 2 X 6 CrNiMoTi 17 12 2 X 6 CrNiMoNb 17 12 2	1.4541 1.4550 1.4401 1.4404 1.4571 1.4580	1020 to 1100			
X 2 CrNiMoN 17 13 3	1.4429	1040 to 1120			
X 2 CrNiMo 18 14 3 X 5 CrNiMo 17 13 3	1.4435 1.4436	1020 to 1100			
X 2 CrNiMoN 17 13 5	1.4439	1040 to 1120			
<p>1) When heat treatment forms part of further processing of the product, an attempt shall be made to achieve the lower values of the range specified for solution annealing. If hot working has been carried out at a temperature of at least 850 °C or if the product has been cold worked, the temperature of renewed solution annealing may be 20 K less than the lower limit for solution annealing.</p> <p>2) If the cooling is sufficiently rapid.</p>					

Table 6. **Types of condition of tubes**

Symbol	Type of condition	Surface finish	Notes
c1	Hot worked, heat treated ¹⁾ , descaled	Metallically clean	
c2	Hot worked, heat treated ¹⁾ , pickled		
f	Mechanically or chemically descaled, cold worked, not heat treated	Metallically bright-drawn, much smoother than for conditions c1 and c2	Cold working without subsequent heat treatment modifies the properties depending on the degree of working; this applies in particular to austenitic steel tubes.
g	Cold worked, heat treated, not descaled	Scaled	Suitable only for components which will be descaled or worked.
h	Cold worked, heat treated and pickled	Metallically bright-pickled, smoother than for condition c2	Especially suitable for grinding and polishing.
m	Cold worked and free from scale, heat treated	Metallically bright-annealed, smoother than for condition h	
n2	Cold redrawn (polished-drawn), bright heat treated	Metallically bright-annealed, smoother than for condition h or m	
o	Ground	Metallically bright-ground; the type and degree of grinding shall be agreed at the time of ordering.	Conditions h, m or n2 are generally used as starting condition ²⁾ .
p	Polished	Metallically bright-polished; the quality and type of polishing shall be agreed at the time of ordering.	
<p>1) See also subclause 5.2.</p> <p>2) ● The order shall specify whether grinding or polishing is to be internal or external, or internal and external.</p>			

Table 7. **Summary of scope of test programme and documents on materials testing**
(see figure 1 for sampling points and location of test pieces; see subclause 6.3.1 for batch size)

Testing			Scope of test programme		Responsibility for carrying out the tests	Type of documents on materials testing
No.	Type of test	As in subclause	Test class 1	Test class 2		
1	Cast analysis	5.3.1	Per cast or casting unit		Manufacturer	DIN 50 049 - 2.2 1)
2	Tensile test at ambient temperature	6.3.1.2 6.4.1 6.5.1	One test piece taken from one sample tube per batch 2)		By agreement	DIN 50 049 - 3.1 A or DIN 50 049 - 3.1 B or DIN 50 049 - 3.1 C or DIN 50 049 - 3.2 A or DIN 50 049 - 3.2 C
3	Impact test	6.3.1.2 6.4.2 6.5.3	For wall thicknesses ≥ 20 mm		By agreement	DIN 50 049 - 3.1 A or DIN 50 049 - 3.1 B or DIN 50 049 - 3.1 C or DIN 50 049 - 3.2 A or DIN 50 049 - 3.2 C
			1 set of 3 individual test pieces per sample tube			
4	Flattening test, ring expanding test (or drift expanding test) or ring tensile test (see table 8)	6.3.1.4 6.3.1.5.1 6.4.3 6.5.4 6.5.5 6.5.6 6.5.7	For wall thicknesses ≤ 40 mm		By agreement	DIN 50 049 - 3.1 A or DIN 50 049 - 3.1 B or DIN 50 049 - 3.1 C or DIN 50 049 - 3.2 A or DIN 50 049 - 3.2 C
			1 test piece from both ends of sample tube	1 test piece from one end of each tube or factory length 4)		
5	Non-destructive testing of tube ends	6.3.1.5.2 6.5.12	For wall thicknesses > 40 mm		Manufacturer	DIN 50 049 - 3.1 B
			—	All tubes		
6	Leak tightness test	6.3.1.6 6.5.10	All tubes		Manufacturer	DIN 50 049 - 2.1 1)
7	Visual examination	6.3.1.6 6.5.11	All tubes		By agreement	DIN 50 049 - 3.1 A or DIN 50 049 - 3.1 B or DIN 50 049 - 3.1 C or DIN 50 049 - 3.2 A or DIN 50 049 - 3.2 C
8	Materials identity test	6.3.1.6 6.5.17	All tubes		Manufacturer	DIN 50 049 - 2.1 1)
9	Check on dimensions	6.3.1.6 6.5.15 6.5.16	All tubes		By agreement	DIN 50 049 - 3.1 A or DIN 50 049 - 3.1 B or DIN 50 049 - 3.1 C or DIN 50 049 - 3.2 A or DIN 50 049 - 3.2 C
10	Non-destructive testing of tube wall	6.3.1.5.3 6.3.1.7 6.5.13	By agreement	All tubes 5)	Manufacturer	DIN 50 049 - 3.1 B
11	Hot tensile test 6)	6.3.1.3 6.5.2	By agreement		By agreement	DIN 50 049 - 3.1 A or DIN 50 049 - 3.1 B or DIN 50 049 - 3.1 C or DIN 50 049 - 3.2 A or DIN 50 049 - 3.2 C
12	Product analysis 6)	5.3.2 6.3.1.9 6.4.4 6.5.8	1 product analysis per cast		Manufacturer	DIN 50 049 - 3.1 B
13	Testing for intercrystalline corrosion 6)	5.7.2 6.3.1.8 6.5.9	By agreement		Manufacturer	DIN 50 049 - 3.1 B

1) This certificate may also be included in the next higher stage of document.

2) In the case of tubes with d_a not less than 200 mm or a wall thickness not less than 12 mm, which are to be used for pressure vessel casings, testing shall cover 10% of the test batch.

3) In the case of tubes to be used for pressure vessel casings, testing shall cover 10% of the test batch.

4) In the case of tubes which are to be used for pressure vessel casings and which are to be subjected to ultrasonic examination as specified in *Stahl-Eisen-Prüfblätter* 1915 and 1918, the scope of testing ring test pieces shall be reduced to 10% of the test batch.

5) Only subject to agreement at the time of ordering in the case of tubes with an outside diameter not exceeding 101,6 mm and a wall thickness not exceeding 5,6 mm (see subclause 6.3.1.7).

6) Only subject to agreement between manufacturer and purchaser.

Table 8. Tube dimensions to be considered for the technological tests carried out on test classes 1 and 2 tubes

Tube diameter, in mm		Wall thickness			
Outside	Inside	< 2 mm	$\geq 2 \text{ mm} \leq 16 \text{ mm}$	$> 16 \text{ mm} \leq 40 \text{ mm}$	> 40 mm
$\leq 21,3$	> 15	Flattening test	Ring expanding test 1)	–	–
$\leq 21,3$	≤ 15	Flattening test	Flattening test	–	–
$> 21,3 \leq 146$	> 15	Flattening test	Ring expanding test 1)	Flattening test Impact test 2)	Impact test
$> 21,3 \leq 146$	≤ 15	–	Ring expanding test 1)	Flattening test Impact test 2)	Impact test
> 146	> 100	–	Ring tensile test 3)	Ring tensile test 3) Impact test 2)	Impact test
> 146	≤ 100	–	–	Ring tensile test 3) Impact test 2)	Impact test

1) At the manufacturer's discretion, the drift expanding test may be carried out in place of the ring expanding test.
 2) The impact test shall only be carried out on tubes with a wall thickness not less than 20 mm.
 3) In place of this test, non-destructive testing of the tube ends as described in subclause 6.3.1.5.2 may be carried out by the manufacturer, on tubes with outside diameter exceeding 508 mm.

5.7.2 The data given in table 3 shall apply for the resistance of the steels to intercrystalline corrosion when tested as specified in subclause 6.5.9.

5.8 Type of condition and appearance of surface

5.8.1 The tubes shall be supplied in one of the conditions listed in table 6.

● The selection of the type of condition is left to the manufacturer's discretion.

5.8.2 The tubes shall have an inside and outside surface consistent with the manufacturing process used.

5.8.3 Slight irregularities in the surface resulting from the manufacturing process, such as raised or depressed areas or shallow grooves are permitted, except for condition p (polished), as long as the remaining wall thickness fulfils the requirements specified in subclause 5.11 and the function of the tubes is not impaired.

5.8.4 Proper removal of surface defects using appropriate means (e.g. grinding) is permitted as long as the remaining wall thickness fulfils the requirements specified in subclause 5.11.

5.9 Leak tightness

The tubes shall remain leaktight when tested as specified in subclause 6.5.10.

5.10 Non-destructive testing

5.10.1 The entire wall of test class 2 tubes with an outside diameter exceeding 101,6 mm or a wall thickness exceeding 5,6 mm shall be subjected to an ultrasonic examination as described in *Stahl-Eisen-Prüfblatt* 1915.

Tubes to be used for pressure vessel casings, designed for a permissible working overpressure exceeding 80 bar, shall be tested as specified in *Stahl-Eisen-Prüfblättern* 1915 and 1918.

5.10.2 ●● Subject to agreement at the time of ordering, the entire wall of test class 2 tubes with an outside diameter not exceeding 101,6 mm or a wall thickness not exceeding 5,6 mm and test class 1 tubes may also be subjected to an ultrasonic examination as described in *Stahl-Eisen-Prüfblatt* 1915.

5.11 Dimensions, masses per unit length and permissible deviations

DIN 2462 Part 1 shall apply for the dimensions and masses per unit length of tubes and for permissible deviations.

● DIN 28 180 shall apply for tubular heat exchangers. The order shall follow the pattern of the sample order given in that standard.

5.12 Physical properties

Reference is made to volume 10 of the *Stahleisen-Sonderberichte* (Iron and steel special reports) (see the "Standards and other documents referred to" clause) for guideline data on the physical properties of the steels conforming to the requirements of this standard.

6 Tests to be carried out and documents on materials testing

6.1 General

The tubes accompanied by one of the following documents on materials testing as specified in DIN 50 049:

- document DIN 50 049 – 3.1 A (inspection certificate A);
- document DIN 50 049 – 3.1 B (inspection certificate B);
- document DIN 50 049 – 3.1 C (inspection certificate C);
- document DIN 50 049 – 3.2 A (inspection report A);
- document DIN 50 049 – 3.2 C (inspection report C).

● The type of document required and the test house where acceptance inspection is to be carried out by a third party shall be specified in the order.

6.2 Test site

The tubes shall be tested at the manufacturer's works. Production shall not be unduly disturbed when acceptance inspection is carried out by experts who are not employees of the manufacturer.

6.3 Scope of test programme

6.3.1 The tubes shall be inspected by batches. Table 7 gives a synopsis of the scope of test programme in each case.

6.3.1.1 For the purposes of testing, the tubes shall be divided up by steel grade, cast, test class, dimensions and, if possible, by the type of heat control into batches comprising 100 tubes. The tubes may be divided up by factory lengths.

Remainders of up to 50 tubes may be distributed uniformly across the batches. Quantities and remainders of more than 50 tubes and consignments of less than 50 tubes count as one complete batch.

6.3.1.2 One tube (sample tube) shall be taken from each batch for verifying the mechanical properties of test class 1 or 2 tubes. The following tests shall be carried out on this sample tube:

- 1 tensile test at ambient temperature. In the case of tubes with an outside diameter not less than 200 mm or a wall thickness not less than 12 mm, which are to be used for pressure vessel casings, testing shall cover 10% of the test batch;
- 1 set of test pieces for impact tests in the case of tubes with a wall thickness not less than 20 mm. In the case of tubes to be used for pressure vessel casings, testing shall cover 10% of the test batch.

● Tubes to be used for pressure vessel casings shall be particularly specified in the order stating whether or not the permissible working pressure exceeds 80 bar.

6.3.1.3 ●● If a check of the elevated temperature 0,2% and 1% proof stresses has been agreed at the time of ordering, the test temperature and scope of test programme shall also be agreed.

6.3.1.4 Test class 1 tubes

In the case of tubes with a wall thickness not exceeding 40 mm, a flattening test, ring expanding test or ring tensile test shall be carried out on two test pieces, one taken from each end of the sample tube. At the manufacturer's discretion, a drift expanding test may be carried out in place of the ring expanding test.

A synopsis of the tests to be considered for the relevant tube dimensions given in table 8.

6.3.1.5 Test class 2 tubes

6.3.1.5.1 In the case of tubes with a wall thickness not exceeding 40 mm, a flattening test, ring expanding test or ring tensile test shall be carried out on test pieces taken from one end of each tube or each factory length. At the manufacturer's discretion, a drift expanding test may be carried out in place of the ring expanding test.

6.3.1.5.2 In the case of tubes with wall thicknesses exceeding 40 mm, a non-destructive test as described in subclause 6.5.12 shall be carried out on both ends of each tube, over a length of 25 mm.

6.3.1.5.3 Tubes with an outside diameter exceeding 101,6 mm or a wall thickness exceeding 5,6 mm shall be subjected to non-destructive testing as specified in subclause 6.5.13.

6.3.1.6 Irrespective of the test class, the following tests shall be carried out on all tubes in the batch:

- testing for leak tightness;
- materials identity testing;
- visual examination of the type of condition and surface finish;
- check on dimensions.

6.3.1.6.1 ●● It may also be agreed to carry out the visual examination and check on dimensions of the tubes in accordance with a sampling plan, e.g., as described in DIN 40 080.

6.3.1.7 ●● By agreement, the entire wall of test class 1 tubes or of test class 2 tubes with an outside diameter not

exceeding 101,6 mm and a wall thickness not exceeding 5,6 mm may also be subjected to an ultrasonic examination as described in *Stahl-Eisen-Prüfblatt* 1915.

6.3.1.8 ●● A test for resistance to intercrystalline corrosion may be carried out by agreement. The scope of test programme shall be agreed.

6.3.1.9 ●● If a check of the chemical composition (product analysis) has been agreed, this check shall be carried out on one tube per cast.

6.4 Sampling and sample preparation

The information given in figure 1 shall apply for the sampling points and the test piece location.

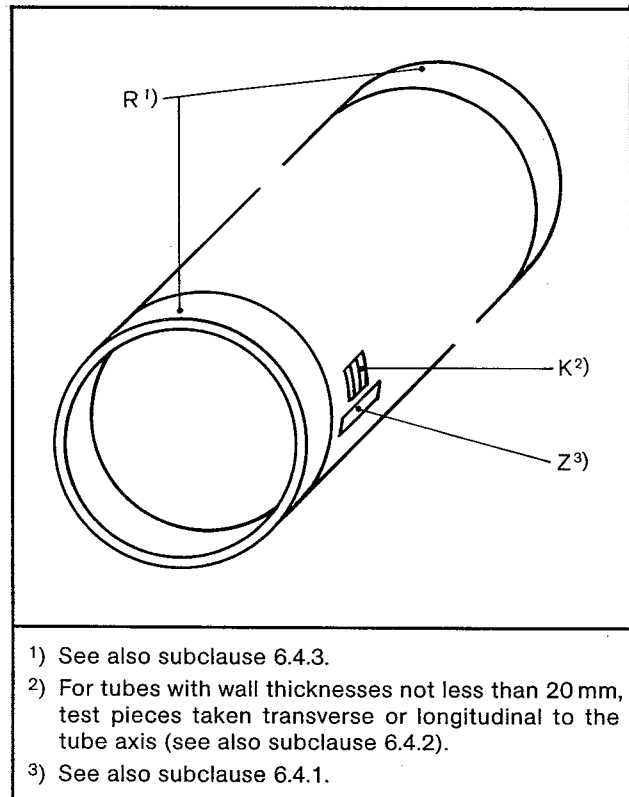

In the illustration above

K = set of 3 ISO V-notch test pieces, as specified in DIN 50 115,

R = ring test piece,

Z = tensile test piece.

Figure 1. Sampling points and location of test pieces

6.4.1 Tensile test

6.4.1.1 For the tensile test, one strip test piece (see DIN 50 140) shall be taken from the sample tube longitudinal to the tube axis. It is permitted to remove local irregularities. The test piece shall not be heat treated and not straightened within the gauge length. In the case of wall thicknesses exceeding 30 mm, at the manufacturer's discretion, circular test pieces (see DIN 50 125) may be taken longitudinal to the tube axis, at a distance of one quarter of the wall thickness from the outside surface or as close to this position as possible.

At the manufacturer's discretion, the tubes may also be subjected to a tensile test in full (see DIN 50 140).

6.4.1.2 In the case of tubes with an outside diameter not less than 200 mm, round or flat test pieces worked on all sides may be taken transverse to the tube axis for the tensile test, if the tube dimensions permit this without straightening of the test piece (see DIN 50 125).

6.4.1.3 As a rule, short proportional test pieces shall be taken for the tensile test.

6.4.2 Impact test

For the purpose of the impact test, a set of three ISO V-notch test pieces shall be taken from the sample tube transverse to the tube axis where the tube dimensions permit this without straightening of the test pieces. Otherwise, the test piece shall be taken longitudinal to the tube axis. In the case of tubes with wall thicknesses exceeding 30 mm, the centre line of the test pieces shall have a distance from the external surface equal to one quarter of the wall thickness or shall be positioned as close as possible to this location.

The test pieces shall be taken and prepared in such a way that the axis of the notch is perpendicular to the tube surface.

6.4.3 Technological tests

In the case of test class 1 tubes, the test pieces for the flattening test described in DIN 50 136, the ring expanding test described in DIN 50 137, the drift expanding test described in DIN 50 135 or the ring tensile test described in DIN 50 138 shall be taken from both ends of the sample tube as specified in subclause 6.3.1.2. In the case of test class 2 tubes, the ring test piece shall be taken from one end of each tube or each factory length.

If factory lengths are subsequently cut into subsections, no further test pieces need to be taken from these subsections provided that it is clearly indicated from which already tested factory length the subsections have been taken. If such identification is not given, the factory lengths shall not be tested; the subsections shall be tested instead. In the case of test class 2 tubes, allocation of ring test pieces to the tube ends from which they have been taken shall be possible.

6.4.4 Chemical composition

For checking the chemical composition by means of a product analysis on the finished tube, the sample chips shall be taken at points uniformly distributed over the entire wall thickness of the tube. A similar sampling method shall be used for spectral analyses. In general, *Stahl-Eisen-Prüfblatt* 1805 shall apply for sampling.

6.5 Procedure

6.5.1 The tensile test shall be carried out as described in DIN 50 140 or DIN 50 145.

6.5.2 If verification of the elevated temperature 0,2% and 1% proof stresses has been agreed, this shall be done as specified in DIN 50 145.

6.5.3 The impact test shall be carried out as specified in DIN 50 115.

6.5.4 The flattening test shall be carried out as specified in DIN 50 136. The test pieces or tube ends shall be flattened until a specified distance between platens H is reached. The following equation shall apply for the distance between platens H , in mm:

$$H = \frac{(1+c)s}{c+s/d_a}$$

where

s is the wall thickness, in mm;

d_a is the outside diameter, in mm;

c is a constant for which 0,10 shall be substituted in the equation. If the ratio s/d_a exceeds a value of 0,25, c shall be substituted by 0,09.

6.5.5 The drift expanding test shall be carried out as described in DIN 50 135, using a tapered mandrel, with the expansion reaching the following values, depending on the

diameter ratio d_i/d_a (d_i being the inside diameter, d_a the outside diameter):

20% for d_i/d_a greater than 0,6,

15% for d_i/d_a not exceeding 0,6.

6.5.6 The ring expanding test shall be carried out as described in DIN 50 137. The test pieces shall be expanded until fracture occurs and shall then be inspected. If a 40% expansion is reached (referred to the inside diameter) the test may be discontinued.

6.5.7 The ring tensile test shall be carried out as described in DIN 50 138.

6.5.8 The chemical composition shall be determined in accordance with the methods specified by the Chemists' Committee of the *Verein Deutscher Eisenhüttenleute* (Society of German Ferrous Metallurgy Engineers) (see the "Standards and other documents referred to" clause).

6.5.9 The resistance to intercrystalline corrosion shall be tested as specified in DIN 50 914.

6.5.10 For the leak tightness test using water as described in DIN 50 104, the test pressure shall be 80 bar. The test pressure shall be maintained for at least 5 seconds.

6.5.10.1 ●● A higher test pressure may be agreed. In no case however shall the safety margin with respect to the 0,2% proof stress drop below 1,1 (see DIN 2413, June 1972 edition, subclause 4.6; $Y' = 0,9$). Where appropriate, this shall also apply in the case of thin-walled tubes with large diameters, even at 80 bar.

6.5.10.2 In the test using air under water, the test pressure shall be 6 bar. The test pressure shall be maintained for at least 5 seconds.

6.5.10.3 In the test using air and a foaming agent, the test pressure shall be 0,3 bar.

6.5.10.4 ●● Unless special agreements have been made at the time of ordering, the choice of the above test methods shall be at the manufacturer's discretion.

6.5.10.5 In place of the hydrostatic pressure test, a non-destructive test (e.g., as specified in *Stahl-Eisen-Prüfblatt* 1925, or a leak detection using helium) may be carried out.

6.5.10.6 ● For tubes with outside diameters less than 6 mm, the type of leak tightness shall be agreed at the time of ordering.

6.5.11 The type of condition and surface finish (surface appearance of the tubes) shall be examined visually on the outside of the tubes and, if possible, on the inside, under appropriate lighting conditions by an inspector having normal vision.

Note. Instead of the visual examination, a different test method may also be used, subject to agreement between manufacturer and purchaser.

6.5.12 In the case of test class 2 tubes with a wall thickness exceeding 40 mm, the entire circumference of the tube ends shall be tested non-destructively as specified in *Stahl-Eisen-Prüfblatt* 1919.

6.5.13 In the case of test class 2 tubes with an outside diameter exceeding 101,6 mm or wall thickness exceeding 5,6 mm, non-destructive testing of the entire tube wall shall be carried out as described in *Stahl-Eisen-Prüfblatt* 1915. Tubes to be used for pressure vessel casings, designed for a permissible working pressure exceeding 80 bar, shall be tested non-destructively as specified in *Stahl-Eisen-Prüfblätter* 1915 and 1918.

6.5.13.1 ●● By agreement, test class 1 tubes or test class 2 tubes with an outside diameter not exceeding 101,6 mm or a wall thickness not exceeding 5,6 mm may be subjected to a non-destructive test of the entire wall as specified in *Stahl-Eisen-Prüfblatt* 1915.

6.5.14 Non-destructive testing shall be carried out by the manufacturer.

●● Subject to prior agreement, the purchaser or a qualified inspector acting on his behalf may be present at the inspection.

6.5.15 The wall thicknesses shall be measured at the ends of the tubes using suitable measuring instruments.

6.5.16 The diameter shall be measured using suitable measuring instruments as a two-point measurement.

6.5.17 The materials identity test shall be carried out in a suitable manner.

6.6 Retests

6.6.1 Tubes not satisfying the requirements when tested as specified in subclauses 6.5.10 to 6.5.16 (leak tightness test, visual examination, non-destructive testing, check on dimensions) and test class 2 tubes when tested additionally as specified in subclauses 6.5.4 or 6.5.5, 6.5.6 or 6.5.7 (flattening test, drift expanding test, ring expanding test or ring tensile test) shall be rejected. The manufacturer shall have the right to take suitable measures to correct defects or deviations found in these tests and to present these tubes for renewed acceptance inspection.

6.6.2 If one of the sample tubes fails the acceptance inspection specified in subclauses 6.5.1 to 6.5.3 and also in subclauses 6.5.4 or 6.5.5, 6.5.6 or 6.5.7 for test class 1 tubes, the manufacturer is justified in repeating the test giving unsatisfactory results on twice the number of test pieces of the same tube. All test pieces shall satisfy the requirements. If the requirements are still not satisfied in the new tests, the tube shall be rejected.

Two further tubes shall be taken from the batch concerned in place of the rejected sample tube and shall be submitted to the tests specified in subclauses 6.5.1, 6.5.3, 6.5.4 or 6.5.5, 6.5.6 or 6.5.7. If the requirement is still not fulfilled, the entire batch shall be considered not to comply with the standard. However, individual testing may be agreed between the parties concerned.

6.6.3 If the unsatisfactory result of testing can be improved by means of heat treatment or other suitable measures, the supplier shall be given the opportunity to present a batch which was rejected, for renewed acceptance inspection. If the test pieces continue to fail to satisfy the requirements, the entire batch shall be considered not to comply with the standard.

6.6.4 Test results attributable to improperly carried out sampling, sample preparation or test procedure or to an accidental and local defect in a test piece shall be deemed invalid.

6.7 Documents on materials testing

6.7.1 Depending on the agreement made at the time of ordering (see subclause 6.1), one of the following documents shall be issued

- DIN 50 049 – 3.1 A (inspection certificate A);
- DIN 50 049 – 3.1 B (inspection certificate B);
- DIN 50 049 – 3.1 C (inspection certificate C);
- DIN 50 049 – 3.2 A (inspection report A);
- DIN 50 049 – 3.2 C (inspection report C).

The type and scope of the tests, the responsibility for carrying out the tests and the type of documentation covering these tests are shown in table 7.

In each case, the technical rule agreed at the time of ordering shall be specified.

6.7.2 The documents shall state the marking of the tubes as specified in clause 7.

7 Marking

7.1 Every tube supplied in accordance with this standard shall be clearly and durably marked at one end, as follows:

- manufacturer's mark;
- steel grade (material number);
- symbol specified in table 6 identifying the type of condition of the tubes;
- an appended symbol S indicating that the tube is of the seamless type, supplemented by code letter X if the tubes have been hot formed from steels 1.4541 and 1.4571;
- 1 or 2 for test class 1 or test class 2;
- for test class 1 tubes, the number of the test batch or the cast number;
- for test class 2 tubes, the tube number or the cast number of tubes with an outside diameter not less than 114,3 mm or the symbol identifying the cast;
- inspector's mark;
- symbol identifying non-destructive testing if testing as specified in subclause 6.5.13 has been agreed.

7.2 Marking as specified in subclause 7.1 shall be made by stamping, embossing or printing.

A different type of marking (e.g. labelling of the bundle of tubes) is permitted for tubes with small outside diameter and/or small wall thicknesses.

7.3 ●● Marking over the entire length of tube may be agreed at the time of ordering.

8 Complaints

8.1 Under current law, a complaint may only be raised against defective tubes if the defects impair their processing and use to a more than negligible extent. This shall apply unless otherwise agreed at the time of ordering.

8.2 It is normal and practical for the purchaser to give the supplier the opportunity to judge whether the complaints are justified, if possible by submitting the tube objected to or samples of the tubes supplied.

Appendix A

A.1 Guideline data relating to creep strength

The following table A.1 gives preliminary guideline data on the creep strength of seamless tubes made from the stainless steels listed below. The values listed in the table represent mean values of the scatter range covered up to the present, and these values will be checked from time to time when the results of further tests become available, and they will be corrected if necessary. It can be assumed on the basis of the data from long term creep tests which are already available that the lower limit of this scatter range for the temperatures listed here is situated approx. 20 % lower than the mean value listed, for the steel grades featured.

Table A.1.

Steel grade		Temperature °C	Creep strength for N/mm ²	
Symbol	Material number		10 000 h	100 000 h
X 5 CrNi 18 10	1.4301	600	122	74
		650	79	45
		700	48	23
		750	29	11
		(800)	(17)	(5)
X 6 CrNiTi 18 10	1.4541	600	115	65
		650	70	39
		700	45	22
		750	28	13
		(800)	(17)	(8)
X 5 CrNiMo 17 12 2	1.4401	600	176	118
		650	111	69
		700	65	34
		750	42	20
		(800)	(24)	(10)

Standards and other documents referred to

- DIN 2413 Steel pipes; calculation of wall thickness with regard to internal pressure
- DIN 2462 Part 1 Seamless stainless steel tubes; dimensions, masses per unit length
- DIN 8528 Part 1 Weldability; metallic materials; concepts
- DIN 8556 Part 1 Filler metals for welding stainless and heat resisting steels; designation, technical delivery conditions
- DIN 17 456 General purpose seamless circular stainless steel tubes; technical delivery conditions
- DIN 28 180 Seamless steel pipes for tubular heat exchangers
- DIN 40 080 Sampling procedures and tables for inspection by attributes
- DIN 50 049 Documents on materials testing
- DIN 50 104 Internal pressure test on hollow products; leak tightness test up to a defined internal pressure; general specifications
- DIN 50 115 Testing of metallic materials; impact test
- DIN 50 125 Testing of metallic materials; tensile test pieces, guidelines for their preparation
- DIN 50 135 Testing of metallic materials; drift expanding test on tubes
- DIN 50 136 Testing of metallic materials; flattening test on tubes
- DIN 50 137 Testing of steel; ring expanding test on tubes
- DIN 50 138 Testing of metallic materials; tensile test on tubes and tube strips
- DIN 50 140 Testing of metallic materials; tensile test on tubes and strips from tubes
- DIN 50 145 Testing of metallic materials; tensile test
- DIN 50 914 Testing stainless steels for resistance to intercrystalline corrosion; copper sulfate-sulfuric acid method; Strauß test
- Stahl-Eisen-Prüfblatt 1805²⁾*
Probenahme und Probenvorbereitung für die Stückanalyse bei Stählen
(Sampling and sample preparation for the product analysis of steels)
- Stahl-Eisen-Prüfblatt 1915²⁾*
Ultraschallprüfung auf Längsfehler von Rohren aus warmfesten Stählen
(Ultrasonic testing of creep resisting steel tubes for longitudinal defects)
- Stahl-Eisen-Prüfblatt 1918²⁾*
Ultraschallprüfung auf Querfehler von Rohren aus warmfesten Stählen
(Ultrasonic testing of creep resisting steel tubes for transverse defects)
- Stahl-Eisen-Prüfblatt 1919²⁾*
Ultraschallprüfung auf Dopplungen von Rohren aus warmfesten Stählen
(Ultrasonic testing of creep resisting steel tubes for laminations)
- Stahl-Eisen-Prüfblatt 1925²⁾*
Elektromagnetische Prüfung von Rohren zum Nachweis der Dichtheit
(Electromagnetic testing of tubes for leak tightness)
- Handbuch für das Eisenhüttenlaboratorium²⁾* (Handbook for the ferrous metallurgy laboratory);
volume 2: *Die Untersuchung der metallischen Werkstoffe*
(Investigation of metallic materials); Düsseldorf 1966;
volume 5: (supplement):
A 4.1 – *Aufstellung empfohlener Schiedsverfahren*
(List of recommended arbitration procedures);
B – *Probenahmeverfahren* (Sampling methods);
C – *Analysenverfahren* (Methods of analysis);
most recent edition in each case.
- Stahleisen-Sonderberichte, volume 10²⁾*:
Physikalische Eigenschaften von Stählen und ihre Temperaturabhängigkeit; Polynome und graphische Darstellungen
(Physical properties of steels and their dependence on temperature; polynomials and graphic representations)

Previous editions

DIN 17 440: 01.67, 12.72

Amendments

The following amendments have been made in comparison with the December 1972 edition of DIN 17 440.

- The specifications for tubes have been excluded from the field of application of DIN 17 440. These specifications, according to manufacturing process and level of requirements, are now dealt with in Standards DIN 17 455 to DIN 17 458.
- The layout of the present standard has been harmonized with that of recently published standards for tubes made from other steel groups.
- Where applicable, the symbols (see table in the Explanatory notes) and specifications relating to chemical composition, mechanical properties and heat treatment have been adopted from DIN 17 440, July 1985 edition.

²⁾ Obtainable from *Verlag Stahleisen mbH*, Postfach 82 29, D-4000 Düsseldorf 1.

Explanatory notes

In response to a request from the tube manufacturers, following the procedure applied for other steel groups, stainless steel tubes are no longer specified in DIN 17440, but are covered by a series of standards which deal separately with processes of tube manufacture (welded or seamless) and fields of application (general purpose tubes and tubes subject to special requirements). The reasons given when making the request were that

- not all the steels covered in DIN 17440 are used for tubes;
- there are a number of specifications particular to tubes (e.g., relating to testing);
- the number of footnotes may be reduced thereby making the standard more suitable for data processing, and
- the revision of the standards, and consequently a more rapid up-dating to the latest state of the art, will also be simplified.

In accordance with this concept, this standard deals only with seamless circular austenitic stainless steel tubes subject to special requirements (e.g. construction of pressure vessels, chemical plant and pipework).

It was agreed that, where applicable, all specifications agreed for DIN 17440, July 1985 edition, would also be adopted for DIN 17455 to DIN 17458.

Of the austenitic steel grades listed in DIN 17440, December 1972 edition, X 5 CrNi 18 12 *) (1.4303), X 2 CrNiMoN 17 12 2 *) (1.4406) and X 2 CrNiMo 18 16 4 *) (1.4438) steels are not covered by this standard, whilst X 2 CrNiMoN 17 13 5 *) (1.4439) steel has been added.

As the symbols for the steel grades differ from those specified in DIN 17440, December 1972 edition, following the specifications for the chemical composition, and in accordance with DIN 17440, July 1985 edition, a compilation of the material numbers, which have not changed, and the previous and new symbols is given below in tabular form. It is expressly noted that the symbols used in DIN 17440, December 1972 edition, may still be used during the period of validity of this standard.

Material number	Previous symbol from DIN 17440, December 1972 edition	New symbol
1.4301	X 5 CrNi 18 9	X 5 CrNi 18 10
1.4306	X 2 CrNi 18 9	X 2 CrNi 19 11
1.4311	X 2 CrNiN 18 10	X 2 CrNiN 18 10
1.4401	X 5 CrNiMo 18 10	X 5 CrNiMo 17 12 2
1.4404	X 2 CrNiMo 18 10	X 2 CrNiMo 17 13 2
1.4429	X 2 CrNiMoN 18 13	X 2 CrNiMoN 17 13 3
1.4435	X 2 CrNiMo 18 12	X 2 CrNiMo 18 14 3
1.4436	X 5 CrNiMo 18 12	X 5 CrNiMo 17 13 3
1.4439¹⁾	X 3 CrNiMoN 17 13 5 ¹⁾	X 2 CrNiMoN 17 13 5
1.4541	X 10 CrNiTi 18 9	X 6 CrNiTi 18 10
1.4550	X 10 CrNiNb 18 9	X 6 CrNiNb 18 10
1.4571	X 10 CrNiMoTi 18 10	X 6 CrNiMoTi 17 12 2
1.4580	X 10 CrNiMoNb 18 10	X 6 CrNiMoNb 17 12 2

1) Not included in DIN 17440, December 1972 edition.

Tubes complying with the requirements of this standard may be supplied as test class 1 or test class 2 tubes. They are distinguished by the extent of testing. Test class 1 tubes are suitable for use in pipework construction; test class 2 tubes for purposes specified in *AD-Merkblatt* (AD Instruction sheet) W2 *Austenitische Stähle* (Austenitic steels). The specifications for test class 2 tubes given in the present standard do not agree in all points with those laid down in *AD-Merkblatt* W2, September 1981 edition; however, the specifications given in the present standard were generally considered more appropriate, and it is hoped that in the revised edition of *AD-Merkblatt* W2 a reference to DIN 17458 with regard to welded tubes will suffice.

Subclause 7.3 of the present standard allows for an agreement to mark the tubes over their entire length. Longitudinal marking of tubes with an outside diameter of 17,2 to 114,3 mm and a wall thickness of 1,6 to 3,2 mm is usual at the time of publication of this standard.

Appendix A of this standard gives preliminary guideline data on the creep strength of seamless tubes made from X 5 CrNi 18 10 (1.4301), X 6 CrNiTi 18 10 (1.4541) and X 5 CrNiMo 17 12 2 (1.4401) steels. It is however important to note that the specified values apply for seamless tubes only, since these values have been verified up to the present only for seamless tubes and for the chemical composition predominantly specified for seamless tubes. In the case of products to be used as tube accessories and subjected to long-time stress, the relevant steel grades specified in *Stahl-Eisen-Werkstoffblättern* 640 *Stähle im Primärkreislauf von Kernenergie-Erzeugungsanlagen* (Steels to be used for components in the primary circuit of nuclear power plants) and 670 *Hochwärmefeste Stähle; Gütevorschriften* (Highly heat resisting steels; quality specifications) shall be used.

*) Symbol as specified in DIN 17440, July 1985 edition.

This standard is related to ISO 2604/2 - 1975, Steel tubes for pressure purposes; quality requirements; wrought seamless tubes, published by the International Organization for Standardization (ISO). In the following table, the steel grades specified in this standard are compared with the austenitic stainless steels specified in ISO 2604/2 - 1975. The comparison is made only with regard to the chemical composition of the steels.

Comparison of austenitic stainless steels as specified in national documents with those specified in ISO 2604/2 - 1975

Source 1)	National documents		ISO 2604/2 - 1975	
	Symbol	Material number	Symbol	2)
DIN 17 458	X 5 CrNi 18 10	1.4301	TS 47	○
DIN 17 458	X 2 CrNi 19 11	1.4306	TS 46	○
SEW 640	X 6 CrNi 18 11	1.4948	TS 48	○
DIN 17 458	X 2 CrNiN 18 10	1.4311	-	
DIN 17 458	X 6 CrNiTi 18 10	1.4541	TS 53	●
SEW 470	X 12 CrNiTi 18 9	1.4878	TS 54	○
DIN 17 458	X 6 CrNiNb 18 10	1.4550	TS 50	●
SEW 670	X 8 CrNiNb 16 13	1.4961	TS 56	○
DIN 17 458	X 5 CrNiMo 17 12 2	1.4401	TS 60	○
DIN 17 458	X 2 CrNiMo 17 13 2	1.4404	TS 57	●
DIN 17 458	X 6 CrNiMoTi 17 12 2	1.4571	-	
DIN 17 458	X 6 CrNiMoNb 17 12 2	1.4580	-	
DIN 17 458	X 2 CrNiMoN 17 13 3	1.4429	-	
DIN 17 458	X 2 CrNiMo 18 14 3	1.4435	TS 58	○
DIN 17 458	X 5 CrNiMo 17 13 3	1.4436	TS 61	○
DIN 17 458	X 2 CrNiMoN 17 13 5	1.4439	-	
SEW 640	X 6 CrNiMo 17 13	1.4919	TS 63	●
SEW 670	X 8 CrNiMoNb 16 16	1.4981	TS β	●
SEW 470	X 12 CrNi 25 21	1.4845	TS 68	×
SEW 470	X 10 NiCrAlTi 32 20	1.4876	TS 69	○

1) DIN 17 458 = specified in DIN 17 458;

SEW 470 = specified in *Stahl-Eisen-Werkstoffblatt 470-76 Hitzebeständige Walz- und Schmiedestähle* (Heat resisting rolled and forged steels);

SEW 640 = specified in *Stahl-Eisen-Werkstoffblatt 640-75 Stähle für Bauteile im Primärkreislauf von Kernenergieerzeugungsanlagen*;

SEW 670 = specified in *Stahl-Eisen-Werkstoffblatt 670-69 Hochwarmfeste Stähle; Gütevorschriften*.

2) This column indicates the degree of agreement with regard to the chemical composition of the steels specified in national documents and those specified in ISO 2604/2 - 1975.

The symbols have the following meaning:

- × complete agreement,
- slight differences,
- significant differences.

International Patent Classification

F 16L 9/16

B 21 C 37/08

E 03 F 3/04

C 22 C 38/40

G 01 M 3/00

G 01 M 19/00